



Power Systems Engineering Research Center

The electric power industry is evolving from its historical business structure. Challenges for success in this demanding business environment are being raised by new market structures and ways of doing business, new technologies, the demands of customers for customized services, strategic choices between centralized and decentralized technologies, institutional changes creating mega-RTOs, a graying industry that needs well-trained power engineers, and new environmental priorities. Yet the basic function of the industry – to produce and to deliver power, safely and reliably – has not changed. The challenges call for new strategies, technologies, analytical capabilities and tools, and operating practices, along with sound public policy guidance.

The Power Systems Engineering Research Center (PSERC) draws on university capabilities to creatively address these challenges. **Its core purpose is to empower minds to engineer the future electric energy system.** Under the banner of PSERC, multiple U.S. universities are working collaboratively toward:

- An efficient, secure, resilient, adaptable, and economic electric power infrastructure serving society
- A new generation of educated technical professionals in electric power
- Knowledgeable decision-makers on critical energy policy issues
- Sustained, quality university programs in electric power engineering.

PSERC provides:

- efficient access to experienced university researchers in an array of relevant disciplines and geographically located across the U.S.

Auction Results for Generator 1 (duration = 1.0 hour)

Block	Capacity (MW)	Marginal Cost (\$/MWh)	Offer Price (\$/MWh)	Quantity Sold (MW)	Selling Price (\$/MWh)	Revenue (\$)	Standby/Start Cost (\$)	Variable Cost (\$)	Earnings (\$)
1	50.0	\$20.00	\$20.00	50.0	\$20.00	\$1000.00	\$500.00	\$1000.00	\$1500.00
2	50.0	\$40.00	\$40.00	50.0	\$40.00	\$2000.00	\$500.00	\$1000.00	\$1500.00
3	10.0	\$40.00	\$60.00	-	-	-	\$50.00	-	-\$50.00
4	10.0	\$50.00	\$80.00	-	-	-	\$50.00	-	-\$50.00
5	10.0	\$50.00	-	-	-	-	-	-	-
Total	100.0			70.0	\$50.00	\$3640.00	\$450.00	\$1800.00	\$1990.00
							- Interest Charge		-\$100.00
									= Total Earnings \$190.00

Auction History (Periods 1 - 1)

Period	Actual System Load (MW)	Qty Sold (MW)	Market Share	Offer Price (\$/MWh)	Selling Price (\$/MWh)	Avg Market Price (\$/MWh)	Earnings (\$)
1	547.0	70.0	12.8%	\$20.00	\$40.00	\$30.00	\$190.00
1 - 1							Cumulative Earnings: \$190.00
							Cumulative Earnings * Exchange Rate (0.0002): \$0.04

Markets research includes experimental methods to test and verify the performance of alternative market designs. PowerWeb is an Internet-based simulation used for experimental testing. It can be accessed at <http://www.pserc.cornell.edu/powerweb>.

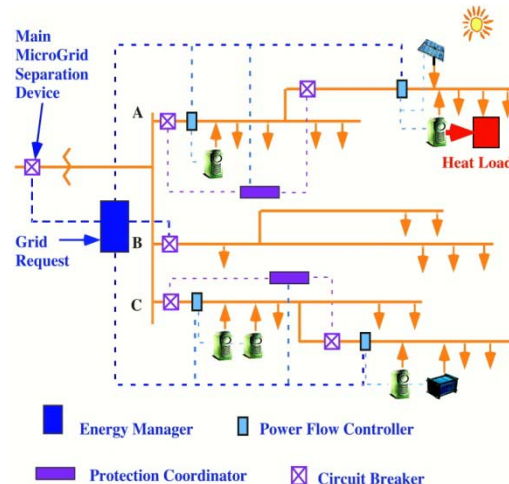

T&D research seeks tools and technologies for enhancing power quality. Research is being conducted on MicroGrids that integrate microsources to ensure stable and reliable power at a grid location.

- leading-edge research in cost-effective projects jointly developed by industry leaders and university experts
- high quality education of future power engineers.

The multidisciplinary expertise of PSERC's researchers includes power systems, applied mathematics, complex systems, computing, control theory, power electronics, operations research, non-linear systems, economics, industrial organization and public policy. We partner with private and public organizations that provide integrated energy services, transmission and distribution services, power system planning, control and oversight, market management services, and public policy development.

Education Program

The undergraduate and graduate power programs at PSERC's collaborating universities produce engineers capable of making substantive contributions in today's complex power industry. By taking innovative research findings to the classroom and involving students in our research, PSERC faculty introduce students to the cutting edge of power system technologies, analytical techniques and industry practices. Not only does PSERC help students become technically prepared for their next job, it also assures that they will be knowledgeable about the challenges and trends transforming the industry. PSERC also facilitates efficient employment searches through industry-student interactions at industry meetings, student involvement in PSERC projects, web site postings, and email announcements.

PSERC's education program also includes professional development. Through short courses, monthly Internet seminars, and on-site seminars, PSERC meets continuing education needs of engineers from our industrial partners. The PSERC website, available at <http://www.pserc.org>, has tutorials, analysis tools and recorded seminars along with papers, reports and presentations by our researchers.

Research Program

PSERC's comprehensive research program spans markets, T&D technologies and systems to find opportunities for advancing high performance electric power systems through better ideas.

Markets Research: Markets research focuses on market design, verification and validation within the context of electricity market restructuring. Representative research topics are active load participation, auction policies and strategies, market mechanisms, restructured market assessment and transmission asset valuation.

Transmission and Distribution Research: This research improves performance of T&D systems by finding new applications for innovative technologies. Representative research topics are automation, intelligent devices and control concepts, management of an aging infrastructure, protection systems, stability and dynamic limits, substation data integration and functionality, and state estimation.

Systems Research: Systems research seeks ways to increase use, efficiency and reliability of increasingly complex and dynamic power systems. Representative research topics are cascading events, complex systems, computational methods for large systems, control schemes, distribution system reliability, risk assessment, security assessment, transfer limits and visualization.

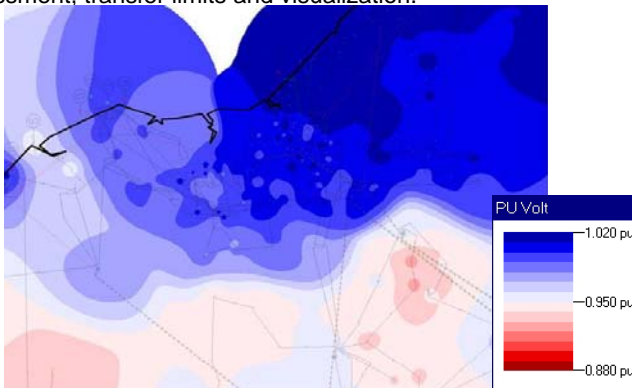

Systems research addresses reliability concerns in power markets. To help system operators maintain system integrity, new display techniques are being studied using human-factor analysis.

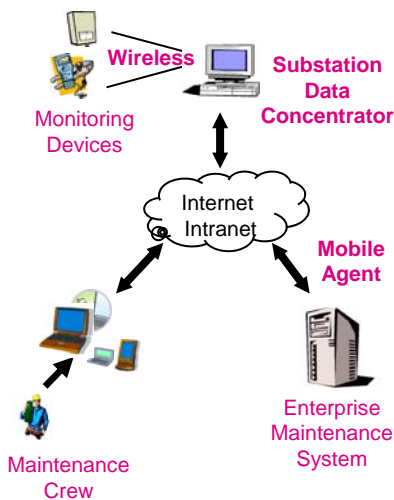

T&D technology research seeks new ways to achieve efficient and reliable power delivery such as through wireless power system monitoring applications and mobile agent processing.



At semi-annual meetings, industry, faculty and students dialog on research projects and education activities, discuss industry challenges, and plan future research. Presentations, tutorials and networking provide new insights and professional development.

Current Industry Members

ABB	Midwest ISO
American Electric Power	National Rural Elec. Coop.
American Transmission Co.	New York ISO
AREVA T&D	New York Power Auth.
Arizona Public Service	Pacific Gas and Electric
Bonneville Power Admin.	PEPCO
British Columbia Trans. Co.	PJM Interconnection
California ISO	PowerWorld Corp.
CenterPoint Energy	Quanta Technology
Duke Energy	RTE - France
Entergy	Salt River Project
EPRI	San Diego Gas & Electric
Exelon	Southern Company
FirstEnergy	Southern California Edison
GE Energy	TVA
Institut de recherche d'Hydro-Québec (IREQ)	Tri-State G&T
ISO New England	U.S. DOE
Midamerican Energy Co.	Western Area Power Adm.

Collaborating Universities

Arizona State	Illinois
Berkeley	Iowa State
Carnegie Mellon	Texas A&M
Colorado School of Mines	Washington State
Cornell	Wichita State
Georgia Tech	Wisconsin
Howard	

For More Information

Visit our web site at <http://www.pserc.org> or contact:

Vijay Vittal, Director
Arizona State Univ. (lead university)
Phone: 480-965-1879
Email: Vijay.Vittal@asu.edu

Dennis Ray, Executive Director
Phone: 608-265-3808
Email: djay@enr.wisc.edu

Systems Research Projects

Systems research concentrates on efficient and reliable operation of the increasingly complex and dynamic power system.

Current Projects (projects in red are new projects in 2010; projects in green began in 2009; remaining projects are about to be completed)

- [The Smart Grid Needs: Model and Data Interoperability, and Unified Generalized State Estimator \(S-39\)](#)
- [Integration of Storage Devices into Power Systems with Renewable Energy Sources \(S-40\)](#)
- [Tools and Techniques for Considering Transmission Corridor Options to Accommodate Large Scale Renewable Energy Resources \(S-41\)](#)
- [Toward a Systematic Framework for Deploying Synchrophasors and their Utilization for Improving Performance of Future Electric Energy Systems \(S-37\)](#)
- [Next Generation On-Line Dynamic Security Assessment \(S-38\)](#)
- [Special Protection Schemes: Limitations, Risks, and Management \(S-35\)](#)
- [Using PMU Data to Increase Situational Awareness \(S-36\)](#)
- [Techniques for the Evaluation of Parametric Variation in Time-Step Simulations \(S-17\)](#)
- [Real-Time Security Assessment of Angle Stability and Voltage Stability Using Synchrophasors \(S-31\)](#)
- [Fast Simulation, Monitoring, and Mitigation of Cascading Failures \(S-32\)](#)
- [Implementation Issues for Hierarchical, Distributed State Estimators \(S-33\)](#)

Completed Systems Stem Projects (titles are linked to the final reports on the PSERC website)

- [Development and Evaluation of System Restoration Strategies from a Blackout \(2009, S-30\)](#)
- [Impact of Increased DFIG Wind Penetration on Power System Reliability and Consequent Market Adjustments \(2009, S-34\)](#)
- [Optimal Allocation of Static and Dynamic VAR Resources \(2008, S-24\)](#)
- [Effective Power System Control Center Visualization \(2008, S-25\)](#)
- [Risk of Cascading Outages \(2008, S-26\)](#)
- [A Tool for On-Line Stability Determination and Control for Coordinated Operating between Regional Entities Using PMUs \(2008, S-27\)](#)
- [A Tool for On Line Stability Determination and Control for Coordinated Operating between Regional Entities Using PMUs: Expanded Testing \(2008, S-27G\)](#)
- [Preventing Voltage Collapse with Protection Systems that Incorporate Optimal Reactive Power Control \(2008, S-28\)](#)
- [Detection, Prevention and Mitigation of Cascading Events – Prototype Implementations \(2008, S-29\)](#)

- Security Enhancement through Direct Non-Disruptive Load Control: [Part I](#), [Part II](#) (2006, S-16)
- [Enhanced State Estimators](#) (2006, S-22)
- [New System Control Methodologies](#) (2005, S-6)
- [Comprehensive Power System Reliability Assessment](#) (2005, S-13)
- [Extended State Estimation for Synchronous Generator Parameters](#) (2005, S-15)
- [Visualization of Power Systems and Components](#) (2005, S-18)
- Detection, Prevention and Mitigation of Cascading Events: [Part I](#), [Part II](#), [Part III](#) (2005, S-19)
- [New Implications of Power System Fault Current Limits](#) (2005, S-20)
- [On-Line Transient Stability Assessment](#) (2005, S-21)
- [Optimal Placement of Phasor Measurement Units for State Estimation](#) (2005, S-23G)
- [Integrated Security Analysis](#) (2003, S-7)
- [Risk-Based Maintenance Allocation and Scheduling for Bulk Transmission System Equipment](#) (2003, S-14)
- [Identification and Tracking of Parameters for a Large Synchronous Generator](#) (2002, S-1)
- [Voltage Collapse Margin Monitor](#) (2002, S-2)
- [Coordination of Line Transfer Capability Ratings](#) (2002, S-8)
- [Power System State Estimation and Optimal Measurement Placement for Distributed Multi-Utility Operation](#) (2002, S-10)
- [Steady State Voltage Security Margin Assessment](#) (2002, S-11)
- [Robust Control of Large-Scale Power Systems](#) (2002, S-12)
- [Impact of Protection Systems on Reliability](#) (2001, S-4)
- [Automated Operating Procedures for Transfer Limits](#) (2001, S-5)
- [Avoiding and Suppressing Oscillations](#) (2000, S-3)

T&D Technologies Research Projects

T&D research improves transmission and distribution systems through use of technology innovations.

Current Projects (projects in red are new projects in 2010; projects in green began in 2009; remaining projects are about to be completed)

- [Micro and Nano Dielectrics for Utility Applications \(T-42\)](#)
- [Verifying Interoperability and Application Performance of PMUs and PMU-Enabled IEDs at the Device and System Level \(T-43\)](#)
- [Communication Requirements and Integration Options for Smart Grid Deployment \(T-39\)](#)
- [PHEVs as Dynamically Configurable Dispersed Energy Storage \(T-40\)](#)
- [Implications of the Smart Grid Initiative on Distribution Engineering \(T-41\)](#)
- [The 21st Century Substation Design \(T-37\)](#)
- [Substation of the Future: A Feasibility Study \(T-38\)](#)
- [Overloading and Optimum Operation of Liquid Filled Power Transformers \(T-25\)](#)
- [Comparative Characterization of Parallel Distribution Sensors Under Field Conditions \(T-35\)](#)

Completed T&D Projects (titles are linked to the final reports on the PSERC website)

- [Characterization of Composite Cores for High Temperature-Low Sag Conductors \(2009, T-33\)](#)
- [Power System Level Impacts of Plug-In Hybrid Cars \(2009, T-34\)](#)
- [Integration of Asset and Outage Management Tasks for Distribution Applications \(2009, T-36\)](#)
- [Satellite Imagery for the Identification of Interference with Overhead Power Lines \(2008, T-28\)](#)
- [Digital Protection System Using Optical Instrument Transformers and Digital Relays Interconnected by an IEC 61850-9.2 Digital Process Bus \(2008, T-29\)](#)
- [Transient Testing of Protective Relays: Study of Benefits and Methodology \(2008, T-30\)](#)
- [Massively Deployed Sensors \(2008, T-31\)](#)
- [Integration of Substation IED Information into EMS Functionality \(2008, T-32\)](#)
- [Reliability-Based Vegetation Management Through Intelligent System Monitoring \(2007, T-27\)](#)
- [Automated Integration of Condition Monitoring with an Optimized Maintenance Scheduler for Circuit Breakers and Power Transformers \(2006, T-19\)](#)
- [Novel Approach for Prioritizing Maintenance of Underground Cables \(2006, T-23\)](#)
- [Risk-Based Maintenance Resource Allocation for Distribution System Reliability Enhancement \(2006, T-24\)](#)
- [Prediction of Flashover Voltage of Insulators Using Low Voltage Surface Resistance Measurement \(2006, T-26G\)](#)
- [Distribution System Electromagnetic Modeling and Design for Enhanced Power Quality \(2005, T-12\)](#)

- [Voltage Sag Effect on Loads in Electric Power Systems](#) (2005, T-16)
- [Enhanced Reliability of Power System Operation Using Advanced Algorithms and IEDs for On-Line Monitoring: Part I, Part II](#) (2005, T-17)
- [Control and Design of Microgrid Components](#) (2006, T-18)
- [Performance Assessment of Advanced Digital Measurement and Protection Systems: Part I, Part II](#) (2006, T-22)
- [Intelligent Substation](#) (2004, T-5)
- [Evaluation of Critical Components of Non-Ceramic Insulators In-Service: Role of Seals and Interfaces](#) (2004, T-14)
- [Smart Sensor Development for Power Transmission and Distribution](#) (2004, T-20)
- [Distributed Electric Energy Storage and Generation](#) (2004, T-21)
- [Corona Discharge Caused Deterioration of All Dielectric Self-Supporting Fiber-Optic Cables](#) (2002, T-1)
- [Differential GPS Measurement of Overhead Conductor Sag and Software Implementation](#) (2002, T-2)
- [Condition Monitoring and Maintenance Strategies for In-Service Non-ceramic Insulators, Underground Cables and Transformers](#) (2002, T-6)
- [Investigation of Fuel Cell Operation and Interaction within the Surrounding Network](#) (2002, T-8)
- [Enhanced State Estimation via Advanced Substation Monitoring](#) (2002, T-9)
- [Accurate Fault Location in Transmission and Distribution Networks Using Modeling, Simulation and Limited Field-Recorded Data](#) (2002, T-10)
- [Power System Monitoring Using Wireless Substation and System-Wide Communications: Part I, Part II](#) (2002, T-11)
- [Personnel Grounding and Safety Issues / Solutions Related to Servicing Telecommunications Equipment Connected to Fiber Optic Cables in Optical Ground Wire \(OPGW\)](#) (2002, T-13)
- [On-Line Peak Loading of Substation Distribution Transformers Through Accurate Temperature Prediction](#) (2001, T-3)
- [Electrical Transmission Line Insulator Flashover Predictor](#) (2001, T-4)
- [Redesign and New Interpretation of Power Acceptability Curves for Three Phase Loads](#) (2001, T-7)

Markets Research Projects

Markets research focuses on market design, verification and validation along with reliability, auctions, asset valuation, market power and decision-making tools.

Current Projects (projects in red are new projects in 2010; projects in green began in 2009; remaining projects are about to be completed)

- **Design and Valuation Design and Valuation of Demand Response Mechanisms and Instruments for Integrating Renewable Generation Resources in a Smart Grid Environment (M-23)**
- **Interactions of Multiple Market-based Energy and Environmental Policies in a Transmission-Constrained Competitive National Electricity Market (M-24)**
- **Coupling Wind Generation with Controllable Load and Storage: A Time-Series Application of the SuperOPF (M-22)**
- **PHEVs as Dynamically Configurable Dispersed Energy Storage (T-40)**
- **Technical and Economic Implications of Greenhouse Gas Regulation in a Transmission Constrained Restructured Electricity Market (M-21)**
- **Optimal Electricity Market Structures to Reduce Seams and Enhance Investment (M-9)**
- **Improved Investment and Market Performance Resulting from Proper Integrated System Planning (M-18)**

Completed Projects (titles are linked to the final reports on the PSERC website)

- **[Economic Impact Assessment of Transmission Enhancement Projects \(2009, M-14\)](#)**
- **[Integrating Electric System Planning with Efficient Markets to Provide Adequate Investment \(2009, M-16\)](#)**
- **[Integrated Financial and Operational Risk Management in Restructured Electricity Markets \(2009, M-17\)](#)**
- **[Facilitating Environmental Initiatives While Maintaining Efficient Markets and Electric System Reliability \(2009, M-20\)](#)**
- **[Evaluation of Alternative Market Structure and Compensation Schemes for Incenting Transmission Reliability and Adequacy Related Investments \(2008, M-11\)](#)**
- **[Reliability, Electric Power, and Public Vs. Private Goods: A New Look at the Role of Markets \(2008, M-12\)](#)**
- **[Agent Modeling for Integrated Power System, Power and Fuel Market Simulation \(2008, M-13\)](#)**
- **[Tools for Assessment of Bidding into Electricity Auctions \(2008, M-15\)](#)**
- **[Modeling Market Signals for Transmission Adequacy Issues: Valuation of Transmission Facilities and Load Participation Contracts in Restructured Electric Power Systems \(2007, M-6\)](#)**
- **[Reliability Assessment Incorporating Operational Considerations and Economic Aspects for Large Interconnected Grids \(2007, M-8\)](#)**
- **[Uncertain Power Flows and Transmission Expansion Planning \(2007, M-10\)](#)**
- **[Electric Power Industry and Climate Change – Discussion Paper \(2007, M-19\)](#)**

- [Market Redesign: Incorporating the Lessons Learned from Actual Experiences for Enhancing Market Design](#) (2005, M-4)
- [Software Agents for Market Design and Analysis](#) (2005, M-5)
- [Structuring Electricity Markets for Demand Responsiveness: Experiments on Efficiency and Operational Consequences](#) (2004, M-7)
- [Market Interactions and Market Power](#) (2003, M-3)
- [Market Mechanisms for Competitive Electricity](#) (2002, M-2)
- [Reactive Power Support Services in Electricity Markets](#) (2000, M-1)