

Human Factors Analysis of Power System Visualizations

Thomas J. Overbye
Dept. Elect. & Comp. Eng.
Overbye@ece.uiuc.edu

Douglas A. Wiegmann
Institute of Aviation
dwiegman@uiuc.edu

Aaron M. Rich
Institute of Aviation
am-rich@uiuc.edu

Yan Sun
Dept. Elect. & Comp. Eng.
yansun@uiuc.edu

University of Illinois at Urbana-Champaign
Urbana, IL 61801 USA

Abstract

This paper describes an experimental approach to formally testing the usability of different power system visualizations. In particular, the ability of participants to assess and correct power system voltage problems was tested. Participants were divided into three groups: the first group only saw tabular data, the second group one-line data, while the third group saw one-line data and a color voltage contour. The time to acknowledge the voltage violations and the time to correct the violations were assessed.

1. Introduction

One area in need of new research is the visualization of electric power system operation and analysis information. For the most part the visualization tools encountered by many power system operators and engineers have evolved little beyond tabular displays and the one-line diagram. In a typical utility control center system quantities such as power flows and voltages are usually represented either as analog fields on a set one-line diagram consisting of all the utility's substations, or as entries in tabular list displays. An overview of the system is usually only available on a static map board with the only dynamic data shown using different colored lights.

This needs to change. Restructuring is resulting in the creation of much larger markets. Rather than transacting with their neighbors, utilities are buying and selling in a transcontinental market. Restructuring is resulting in the creation of much larger markets under the control of a single system operator. This will result in even more buses and other devices to monitor and control. Simultaneously, the entry of many new players into the market and the increase in power transfers will result in even more data to manage. Finally, electric grid operators will come under increased scrutiny since their decisions, such as whether to curtail particular transactions, can have a tremendous financial impact on market participants. Power system analysis will need to be modified in a number of different ways to handle these new challenges. One such modification is in how system information is presented to the user

Earlier work has, of course, been done in the area of developing visualization techniques to aid in interpreting power system data, although most have not yet actually made it into the hands of practicing engineers. Several recent examples are described in [1]-[9]. The purpose of the present paper is slightly different, but we believe complimentary to these earlier works. Rather than presenting new visualization techniques, our goal is to describe initial experiments designed to provide at least a preliminary formal assessment of whether these newer visualization techniques are actually effective.

2. Experimental Setup

In attempting to formally assess visualization effectiveness at least three issues must be considered. The first issue is determination of the task. That is, what is the user trying to accomplish. Of course in the area of power system operations and analysis there are a wide variety of different tasks. The tasks of the system planner are substantially different from the tasks of the system operator, which are in turn quite different from those of the marketer or the engineer making presentations to regulators. In this paper the task we focused on was monitoring and control of bus voltage levels from either an operator or an operational planning perspective.

The second issue is how to assess whether the visualization helped the user to better perform a task or a set of tasks. Effective task assessment requires a rather specific knowledge of the ultimate goal. In our area of voltage monitoring and control, we defined the goal to be maintaining the bus voltage magnitudes above a specified threshold. More specifically, following a disturbance we were interested in how quickly the user was able to restore the bus voltages to acceptable levels.

The third issue is how closely the experimental setup matches what actually occurs in practice. The goal in the setup of this experiment was to provide results that would help to design the next generation displays for use by either electric utility operators or operational planning engineers. Therefore in the contextual setup of the experiment our goal was to at least roughly approximate a utility control environment in which an operator responds to a system voltage disturbance, such as the one faced by

the Delmarva Power and Light (DPL) operators on July 6th 1999 during which their system experienced a near voltage collapse following the loss of the Indian River 2 generator [10].

To completely replicate such a situation, and then test the response of the operators to various system visualizations would obviously be quite difficult. In the initial stages of the research project reported here our experimental setup was admittedly a far cry from a control center environment, in which experienced operators or engineers monitor and control a system of which they are quite familiar using displays they've used for years. Nevertheless, we believe our experimental setup to be viable and a good platform for future enhancements.

For test participants we used thirty University of Illinois upper level undergraduates or graduate students majoring in electrical and computer engineering. The students had a good familiarity with basic electrical engineering concepts, such as voltage and impedance, but for the most part were not well versed in power system operations. The experiment was performed using a small 30 bus power system modeled with a modified version of PowerWorld Simulator [11].

During the course of the experiment the 30 bus system was subjected to a variety of different contingencies, each causing low voltage (defined as being below 0.95 per unit) at one or more buses. All but one of these contingencies involved line outages; the remaining contingency was a generator outage. Following each contingency the participants needed to perform two tasks: 1) acknowledge all the low voltage violations, and 2) switch in one or more capacitors in order to correct the low voltage violations. The system had a total of seven capacitors, all initially out-of-service, and was designed so each contingency could be corrected with the insertion of a single capacitor. The students were told to assume that the impedance of each transmission line was proportional to its length on the system one-line diagram, and that the capacitor that was electrically closest was always the correct choice.

Each participant saw one of three different visualizations of the system, *Tabular*, *Online* or *Contour*. As shown in Figure 1, the Tabular group only saw a tabular visualization of the system voltages and capacitors. The leftmost column on the display showed the 30 bus voltage magnitudes, sorted by bus number, while the column immediately to its right showed the status of the seven capacitors, again sorted by bus number. The remaining column showed the line(s) outaged by the contingency (this data was needed for the students to correctly determine the electrically closest capacitor in the post-contingency system). Voltages below the 0.95 threshold were shown using a red font, while those above this threshold were shown in blue. Following each contingencies the participants first had to acknowledge all

the low voltage violations by clicking anywhere in the bus's row. For each of the groups the computer continually "beeped" until all the voltage violations were acknowledged. Then they had to correct the voltage violation by clicking on one or more capacitors to change the capacitor's status. The tabular group did have access to a static system one-line diagram shown on a piece of paper taped to their desk. This diagram was identical to the one-line seen by the Online and Contour groups except it was obviously not dynamic and hence did not show the bus voltage magnitudes.

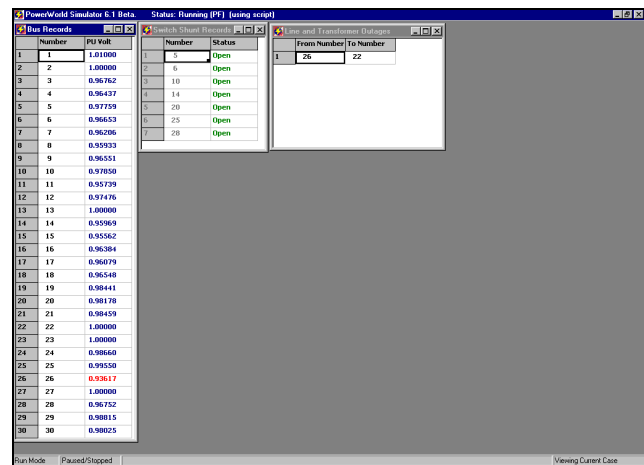

Figure 1: Tabular Group View of the 30 Bus System

As shown in Figure 2, the Online group only saw a dynamic one-line visualization of the system, with the bus voltage magnitude shown immediately to the right of the bus on the one-line. Voltages below the 0.95 threshold were drawn using a red font, while those above the threshold were drawn in black. Again, following each contingency the participants first had to acknowledge all the low voltage violations. This was done by clicking on the voltage magnitude field on the one-line. Then they had to correct the voltage violation by clicking on the capacitor's circuit breaker symbol to change its status. Lines outaged by each contingency were drawn on the one-line using a dashed line (e.g., line 22 to 26 in Figure 2).

As shown in Figure 3, the Contour group saw the exact same representation as the Online group except in addition to seeing the voltage magnitude fields on the one-line, their one-line also contained a color contour of the voltage magnitudes [12]. The contour color was chosen so buses with voltages below the threshold had a dark blue contour, while those above the threshold were contoured using a light cyan or yellow. The low voltage acknowledgement and capacitor switching procedures were identical to the Online group.

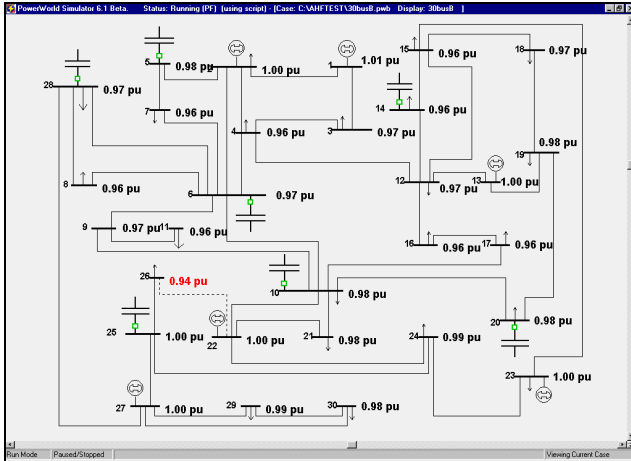

Figure 2: Oonline Group View of the 30 Bus System

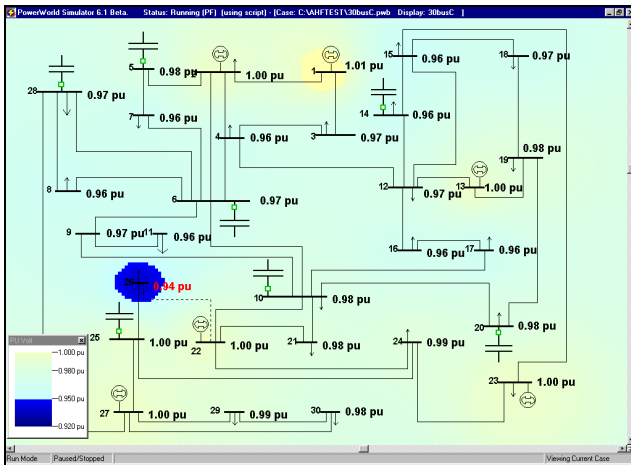

Figure 3: Contour Group View of the 30 Bus System

3. Results and Discussion

In the present experiment, the task of identifying and resolving low-voltage violations required several procedural steps and mental operations (albeit in simplified form compared to “real world” situations). Such operations and procedures included the detection and acknowledgement of the low bus voltages, as well as the identification and closure of the electrically closest capacitor to the low voltage buses that would resolve the incident.

According to the well-established *proximity compatibility principle*, these procedures and mental operations are likely to be facilitated by one-line diagrams and color contouring when information needs to be integrated to perform a task [13]. That is, *high display proximity*, or highly integrated information, helps in tasks with high mental proximity. However, to the extent that information must be treated separately (low mental proximity, as when one must focus on one variable and

ignore values of others), the benefit of the high-proximity display will likely be reduced, if not reversed [14].

This reversed-benefit of integrated displays was evidence in the present study by participants’ response latencies to the low-voltage alarms. In general, participants in the Tabular group had quicker acknowledgement times than participants in the both the Oonline and Contour groups. These differences are depicted in Figure 4 and were confirmed by a one-way between-groups ANOVA that revealed a significant effect for display condition, $F(2,21) = 4.10, p < .05$. Apparently, the process of detecting and acknowledging low voltage alarms required focused attention on one dimension of the display which was facilitated by the tabular format and somewhat hindered by the highly integrated one-line diagrams.

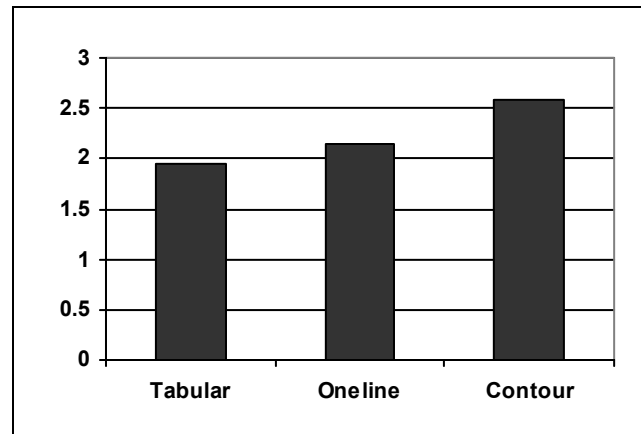

Figure 4: Time in Seconds to Acknowledge All Violations

In contrast to low voltage acknowledgement times, however, participants in the Oonline and Contour groups were more than twice as fast in solving low voltage problems than participants in the Tabular group, $F(2,21) = 41.30, p < .001$. The average amount of time required to resolve low voltages after all violations had been acknowledge is depicted in Figure 5. As expected, the one-line diagrams effectively integrated the relative location of buses and system capacitors, allowing for the electrically closest capacitors to the low voltage buses to be quickly identified. This finding corroborates the results of previous research on other integrated displays (e.g., engine parameter displays) showing that high display proximity produces an emergent feature or Gestalt that directly serves the integration of task requirements and facilitates the parallel processing of information [15].

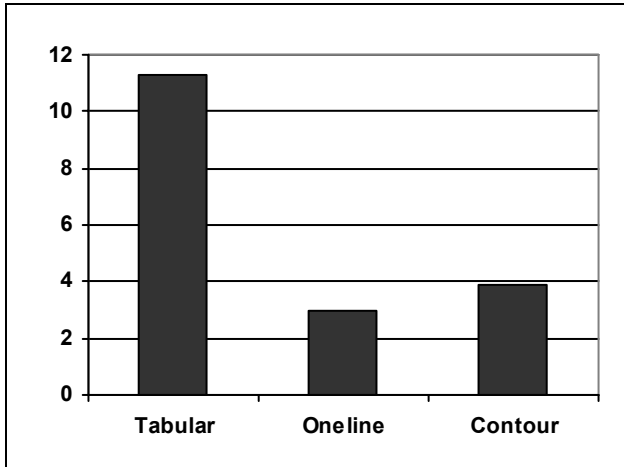

Figure 5: Time in Seconds to Completely Correct Low Voltages

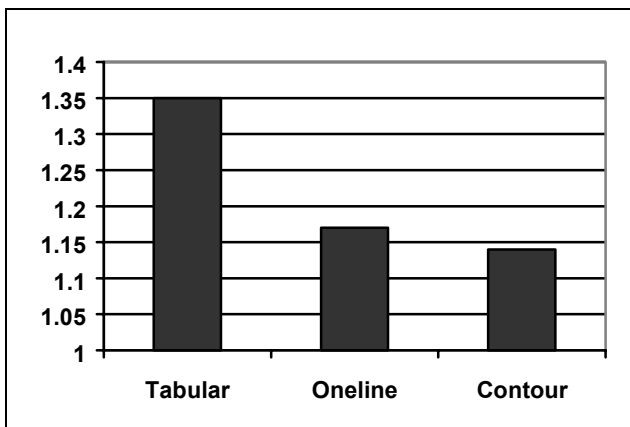

Figure 6: Mean Number of Capacitors Closed

In addition to facilitating quicker solutions to voltage violations, the one-line diagrams also reduced the number errors or capacitors closed when attempting to correct the low voltages, $F(2,21) = 7.56$, $p < .05$. As illustrated in Figure 6, participants in the Tabular group closed significantly more capacitors when attempting to correct

the voltage problems. This finding is noteworthy because previous reaction-time research has shown a *speed-accuracy trade-off*. As people respond more rapidly, they tend to make more errors [16]. This reciprocity between response latency and errors, however, was not evident in the present study. This finding indicates that participants in the Oneline and Contour groups were not just quickly and haphazardly selecting capacitors. Rather, they were more able to identify and closed the correct capacitor on their first attempt to remedy voltage violations than were participants in the Tabular group.

A final comment should be made about the apparent lack of additional benefit afforded by the color contouring used in the present experiment. The performance of participants in the Contour group did not differ markedly from the performance of participants in the Oneline group. One reason for this observation may simply be that color contouring was not needed to perform the tasks used in this experiment. Although the color contours increased the saliency of both the location and severity of the low voltages, this saliency made not have been necessary in the small 30 bus testing scenario used here.

Another issue that may have impacted the results was the increased time necessary to refresh the contour display. Following each voltage acknowledgement the displays needed to be refreshed. For the Tabular and Oneline group this refresh was quite fast, taking just 25 ms for the Tabular display and 50 ms for the Oneline display. For the Contour group the refresh was also relatively fast but there was a very perceptible latency of about 200 ms between the time the user acknowledged the violation and the time the display was refreshed. This delay was simply due to the time it took to update and render the contour bitmap on the screen. This latency could certainly account for the time variations shown in Figure 4 and at least some of the response latency difference in Figure 5 between the Oneline and Contour groups.

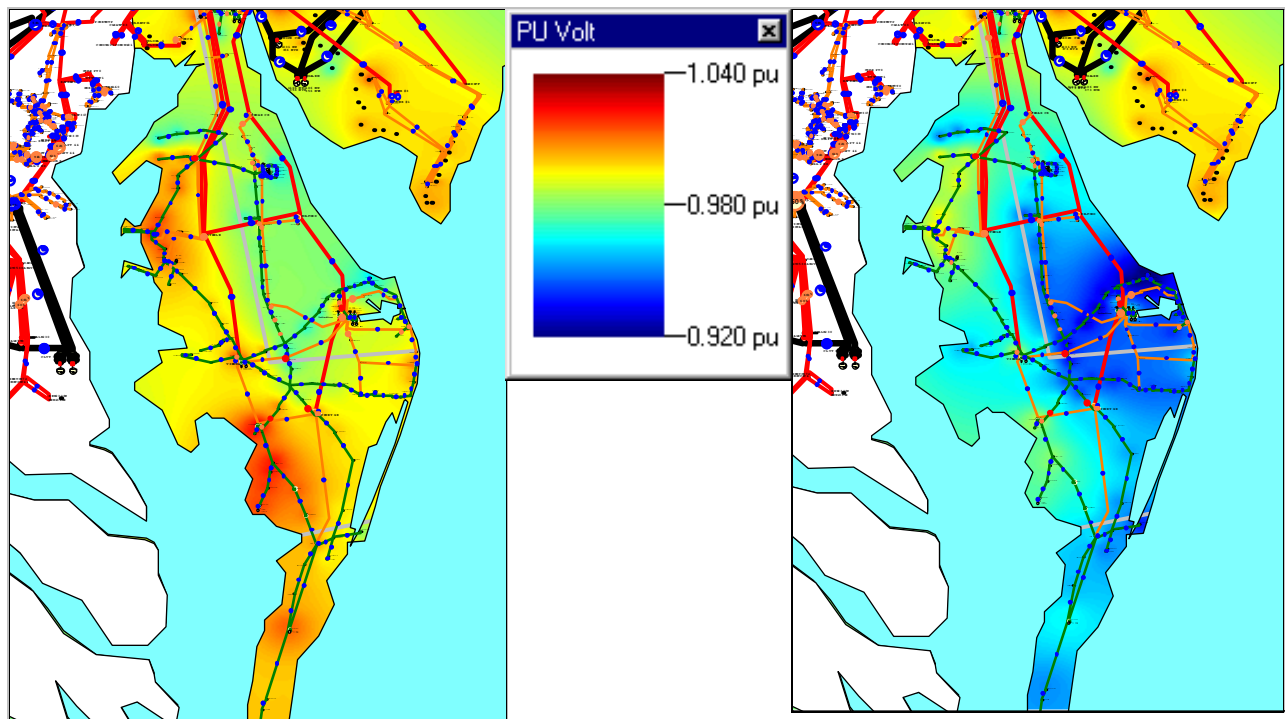

Figure 7: Contours of the voltage variation in approximately 150 of the Delmarva Power and Light (DPL) 69 kV voltages before (left) and after the outage of the 85 MW Indian River 2 Generator on July 6th 1999.

As to whether contour will ultimately prove to be beneficial, we would certainly hypothesize that it is dependent upon system size. With 30 buses it is possible to display the bus voltage magnitude fields on a one-line with sufficient size that it is relatively easy for the user to get a good conceptual mapping of the problem voltage areas. With a larger case this would probably be substantially more difficult. For example Figure 7 shows a one-line/contour of the DPL system showing several hundred buses. Superimposed is a color contour showing the hypothesized voltage levels immediately before and after the Indian River 2 generator outage. From the contours the area of low voltages after the outage seems to be immediately clear. Trying to convey this same information using one-line fields, or tabular displays would appear to be much more difficult. Future experiments are needed to help address these issues.

Even on the small 30 bus system tested here it is possible that the contouring did affect performance in more subtle ways that are not evident in the present data. For example, contouring may have influenced participants' response strategies, such as the order in which they acknowledged violations or selected capacitors to close. One hypothesis which we are currently investigating is that in cases with multiple low voltages the contours subconsciously helped the users focus initially on the areas

with the most pronounced contours, corresponding to the areas of the system with the lowest voltage magnitudes. More fine-grained testing and analyses are ongoing to examine these issues.

4. Conclusion

At first glance each of the three methods appears to offer some benefit. The Tabular group were quickest in acknowledging the voltage violations, the Oneline group were quickest in correcting the problems, and the Contour group made the best capacitor choices. However, the slight time savings the Tabular group had in acknowledgement (a savings of less than a second) was greatly offset by the overall longer time it took for them to completely correct the voltage problems – almost three times as long as the other groups – and the larger number of capacitor switchings they required. Therefore at least for systems with thirty buses using the one-line approach with or without contours appears to be significantly better than a purely tabular approach. Benefits of contouring over a pure one-line approach were not evident with the 30 bus system. More experiments are needed to determine whether the contour approach is more useful with larger systems.

5. Acknowledgement

The authors would like to acknowledge the support of NSF through its grant NSF EEC 96-15792, PSERC (Power System Engineering Research Center), and the U.S. Department of Energy through the CERTS program. The authors would also like to thank the University of Illinois students who participated in this study.

6. References

- [1] P.M. Mahadev, R.D. Christie, "Minimizing User Interaction in Energy Management Systems: Task Adaptive Visualization," *IEEE Transactions on Power Systems*, Vol. 11, No. 3, pp. 1607-1612, August 1996.
- [2] L.D. Christie, "Toward a Higher Level of User Interaction in the Energy Management Task," *Proceedings of the IEEE International Conference on Systems, Man and Cybernetics*, San Antonio, TX, October 2-5, 1994.
- [3] P.R. D'Amour, W.R. Block, "Modern User Interface Revolutionizes Supervisory Systems," *IEEE Computer Applications in Power*, January 1994, pp.34-39.
- [4] K. Ghoshal, L.D. Douglas, "GUI Display Guidelines Driving Winning SCADA Projects," *IEEE Computer Applications in Power*, April 1994, pp. 39-42.
- [5] G.P. de Azevedo, C.S. de Souza, B. Feijo, "Enhancing the Human-Computer Interface of Power System Applications," *IEEE Transactions on Power Systems*, Vol. 11, No. 2, pp. 646-653, May 1996.
- [6] P.M. Mahadev, R.D. Christie, "Envisioning Power System Data: Concepts and a Prototype System State Representation," *IEEE Transactions on Power Systems*, Vol. 8, No. 3, pp. 1084-1090, August 1993.
- [7] M.D. Anderson, H.J. Pottinger, C.M. Schroeder, R. Adapa, "Advanced Graphics Zoom in on Operations," *IEEE Computer Applications in Power*, pp. 25-28, April 1993.
- [8] T.J. Overbye, J.D. Weber, "Visualization of Power System Data", *Proc. 33th Hawaii International Conference on System Sciences*, Maui, HI, January 2000.
- [9] T.J. Overbye and J.D. Weber, "New Methods for the Visualization of Electric Power System Information", accepted for presentation at InfoVis 2000, October, 2000, Salt Lake City, UT.
- [10] Interim Report of the U.S. Department of Energy's Power Outage Study Team, January 2000, <http://tis.eh.doe.gov/post/interim.pdf>.
- [11] <http://www.powerworld.com>
- [12] J.D. Weber, T.J. Overbye, "Voltage Contours for Power System Visualization," *IEEE Trans. on Power Systems*, Vol. 15, February, 2000, pp. 404-409
- [13] C.D. Wickens, A.D. Andre, "Proximity compatibility and information display: effects of color, space, and objectness of information integration," *Human Factors*, vol. 32, 1990, pp. 61-77.
- [14] C.M. Carswell, C.D. Wickens, "Information integration and the object display: An interaction of task demands and display superiority", *Ergonomics*, vol. 30(3), 1987, pp. 511-527.
- [15] C.M. Carswell, "Graphical information processing: The effects of the proximity compatibility," *Proceedings of the 34th annual meeting of the Human Factors Society*, Santa Monica, CA, 1990, pp. 1494-1498.
- [16] R.W. Pew, "The speed-accuracy operating characteristic," *Acta Psychologica*, vol. 30, 1969, pp. 16-26.