

G. J. Lee, G. T. Heydt, "An interactive - dynamic mechanism conceptualizing the cost and benefit of electric power quality," *Journal of Electric Power Components and Systems*, accepted for publication, 2003.

# An Interactive - Dynamic Mechanism Conceptualizing the Cost and Benefit of Electric Power Quality

Geun-Joon Lee\*  
Chung Buk Provincial University  
Chung Buk, KOREA

\*On leave at Arizona State University

G. T. Heydt  
Arizona State University  
Tempe, Arizona USA

## Abstract

With the deregulation of the electric power energy market, providing power quality has become a more important concern of both power suppliers and customers. Customers require better quality with the development of digitally controlled facilities. However, there is not a specific infrastructure to motivate the design of the power system to achieve a specified level of electric power quality. This paper discusses a power quality interactive - dynamic control mechanism to conceptualize the *cost* and *benefit* of power quality. The basic objective is to provide an engineering infrastructure and procedure that 'gives the right signals' to the power supplier and the customer to balance power quality and cost. A power quality level index vector is utilized in the proposed infrastructure.

## 1. Introduction

With the deregulation of the electric power energy market, providing power quality has become a more important concern of both power suppliers and customers. Customers require better quality with the development of digitally controlled facilities [1-2]. However, there is not a specific infrastructure and procedure to motivate the design of the power system to achieve a specified level of electric power quality. The issues of cost of power quality have been addressed from several vantage points: for example, the cost of power conditioning using dynamic voltage boost technologies appears in [3]. The concept of integrated and distributed power quality enhancements appears in [4]. In a deregulated power market, power quality can be taken as a distinguishing element for which competition in the market may depend [5-6]. A number of surveys have been done (especially internationally) relating the value of power quality, how much customers are willing to pay for enhanced power quality, and how much industrial users are paying for power enhancement equipment (e.g., [7-9]). The special issues of voltage sensitivity of adjustable speed drives, and requirements of the semiconductor manufacturing industry have also attracted a great deal of attention.

Reliability and social policy have been discussed in the popular press as well as technical literature. Reference [10] gives a summary of the complex interactive issues. These issues include:

- *Cascading events*: the potential that small events may cascade into high impact losses and costs.
- *Decision-making*: oftentimes decision makers are skilled at cost control but perhaps less skilled at identifying shortcomings and weaknesses in technological applications.
- *Cost equalization*: equitable distribution of costs.
- *Pareto-optimization*: management of conflicting engineering, ethical, environmental, and social requirements.

Clearly, low cost is a popular consumer and regulator philosophy; however, the recognition of the long-term impact of low cost / low quality needs to be addressed. And, engineering may be brought to bear on the proper balance of cost versus quality.

What seems to have escaped attention is the interaction of the dynamics of power quality requirements, costs, and engineering capabilities. This interaction of costs, viewed as a dynamic system, is the main subject of this paper.

## 2. Costs of power quality

The customers of a power system are categorized into industrial, commercial, and residential. There are typically many rate schedules within each service category depending on power level, voltage level, interruptability, and customer choices. The monthly power bill has traditionally consisted of three main components: a service charge, the energy (kWh) charge, and the power (kW) charge. Under open access, the electric service charge is composed of two major elements:

- Competitive services
- Delivery services.

A competitive supplier of the customer's choice may provide the competitive services in a deregulated environment. The delivery service is provided at regulated rates. Table (1) illustrates these charges for a representative example of a residential monthly electric bill.

Table (1) Representative example of a residential monthly contents and costs of electric power services

	<i>Element</i>	<i>Cost (%)</i>
Competitive services	Generation of electricity (including sales tax)	33.2
	Transmission and ancillary services	5.7
	Meter	2.5
	Meter reading	1.1
	Billing	0.8
	Total competitive services	43.3
Delivery Service (Regulated)	Basic service charge	1.9
	Distribution delivery	43.0
	System benefits	1.2
	Competitive transition charge	6.9
	Environmental surcharge	0.2
	Regulatory assessment	0.1
	Sales tax	3.4
Total delivery services	56.7	
	Total of competitive and delivery services	100.0

As in Table (1), the service charge consists of the cost of power generation, transmission and distribution delivery, metering, billing and other service charges. The largest portion of the example bill is the distribution delivery (43.3%), which consists of the cost of distribution equipment for delivering electricity into the home or business, including lines, poles, transformers, and substations. The distribution delivery charge is larger than the energy cost (generation of electricity: 33.2%). There are no specified items relating to power quality.

The U. S. national costs of service interruptions and other power quality issues have been estimated by various agencies and researchers as three billion [21] to 100 billion US dollars per year [1]. The calculation of this cost is highly variable because there is no clear methodology: the cost may be the cost of industrial interruption and loss; or it may be the cost of equipment to maintain power quality; or it may be the cost of engineering (especially in the distribution sector). Actual energy losses may also be included (for example, active power losses in distribution transformers due to harmonics). The direct economic losses to the nation of power interruptions and inadequate power quality may be viewed as results of inadequate investment [1]. Or these direct economic losses may be viewed as results of customer's failure to pay for the required power quality. To further complicate the calculation, depending on one's point of view, power quality costs might be over- or under-stated. Also note that some customers require real freedom from voltage sags and these customers may not be concerned about harmonic voltage content.

A basic issue in setting distribution system rates is that there seems to be no real mechanism to account for power quality, and to set its proper cost. The present billing system has to reflect the power quality component to compensate for economic losses. The economic losses include:

- Actual industrial production losses
- Costs of equipment to maintain a specified level of power quality
- Loss of business due to interruptions in such commercial sectors as financial services
- Loss of information due to interruptions in information technology businesses
- Loss of revenue to the utility companies
- Nuisance of interruptions in the residential sector.

These losses need to be accounted properly between supplier and customer. The power system has to be planned and operated with specified power quality indices, especially for power quality sensitive customers such as semiconductor manufacturers. Table (2) shows the failure costs of representative customers for the three sectors of system load [11]. The tabulated data indicate that the main costs are in the commercial and industrial sectors.

Table (2) Failure cost of representative customers [12]

Nation	Year	Method	Source	Failure cost (1991, US\$/kWh)		
				Residential	Commercial	Industrial
USA	1985	Actual Loss Survey	Subramanian	3.97 - 6.15	10.69 - 24.4	5.79 - 21.85
Sweden	1986	I/O Analysis	Anderson & Taylor	0.50 - 31.7	11.5 - 109	5.10 - 31.3
Canada	1980	Actual Loss Survey	Ontario Hydro		13.3 - 26.05	7.22 - 26.92

### 3. The design of a power quality level measure

The design of a power quality level is important to the assessment of the adequacy of the system design and investment. Unfortunately, there is no single measure that will accommodate all (and sometimes conflicting) requirements and considerations. Table (3) shows some potential measures. There have been numerous discussions on the subject of measuring power quality (for example, [17]), but most of these measures relate to the quantification of the severity of a given condition or case. The indices do not focus on cost or the measure of the impact of power quality as viewed by the conglomerate consumer. The indices listed in Table (3) are mainly measures of the gross impact of power quality. Chowdhury and Koval [18] relate several of these indices to the impact of power quality on the competitive market. Typical values of SAIDI, SAIFI, and CAIDI are shown in Table (4) (calculated in part from [22] and in part from inquiries to U. S. utilities).

It appears that the measure of power quality should be a vector of quantities each of which capture a specific system phenomenon. This approach allows one to utilize the elements of the power quality vector on a selective basis, using the proper element as needed. The symbol  $\vec{PQ}$  is proposed for this vector.

### 4. Model of PQ investment

In completely deregulated electric market, one can consider the electric power system as the assembly of four entities as in Figure (1). The generating company (GENCO) has a power quality level of  $PQ_{GENCO}$  which includes measures of voltage magnitude, frequency, reliability, and harmonic content. The energy is transmitted by the transmission company (TRANSCO) which has a power quality level of  $PQ_{TRANSCO}$ . The TRANSCO power quality index includes voltage magnitude (especially sags and other disturbances), and possibly harmonic content. The main power quality focus has been in the distribution system because loads that create power quality degradation face the distribution system first. The distribution

system (DISCO) has a power quality level of  $\rho_{DISCO}$ . The DISCO power quality level includes all of the aforementioned problematic conditions.

Table (3) Power quality indices that capture power quality adequacy

<i>Index</i>	<i>Acronym</i>	<i>Definition</i>	<i>Application</i>
System Average Interruption Frequency Index	SAIFI	For momentary interruptions: $(Total\ number\ of\ momentary\ interruptions) / (Total\ number\ of\ points\ of\ delivery\ monitored)$ For sustained interruptions: $(Total\ number\ of\ sustained\ interruptions) / (Total\ number\ of\ points\ of\ delivery\ monitored)$	To assess the impact of service interruptions, by number, duration, or severity.
System Average Interruption Duration Index	SAIDI	$(Total\ duration\ of\ all\ interruptions) / (Total\ number\ of\ points\ of\ delivery\ monitored)$	
System Average Restoration Index	SARI	$(Total\ duration\ of\ all\ interruptions) / (Total\ number\ of\ sustained\ interruptions)$	
Delivery Point Unreliability Index	DPUI	$(Total\ unsupplied\ energy\ in\ MW\cdot min) / (System\ peak\ load\ in\ MW)$	To assess impact of power quality by interrupted energy
System Average RMS (Variation) Frequency Index Voltage Threshold	SARFI <sub>%V</sub>	$(Summation\ of\ the\ number\ of\ customers\ experiencing\ rms < \%V\ for\ variation\ i\ (rms > \%V\ for\ \%V > 100)) / (Total\ number\ of\ customers)$	A method to assess voltage sags
Customer Average Interruption Duration Index	CAIDI	$(SAIDI)/(SAIFI)$	An average (e.g., in minutes) of customer interruption duration
Percent of operating time that system is in compliance with IEEE Std. 519			An assessment of the impact of harmonics on services and losses
Estimated annual energy loss due to harmonic load currents			

Table (4) Typical values of power quality reliability indices in the United States [23]

	<i>Approximate range</i>	<i>Approximate average</i>
SAIDI	120 per year	50 - 450 per year
SAIFI	1.3 per year	0.9 - 4.0 per year
CAIDI	92 minutes	50 - 200 minutes

The main question is how to define the  $\rho$  terms: it appears that not a single measure is valid for all circumstances and to capture all events. For this reason, a vector of power quality levels is proposed for  $\rho$ . A potential definition for  $\rho$  is a vector of the indices listed in Table (3). At this juncture, the definition of  $\rho$  is intentionally fuzzy in order to accommodate most potential power quality engineering procedures.

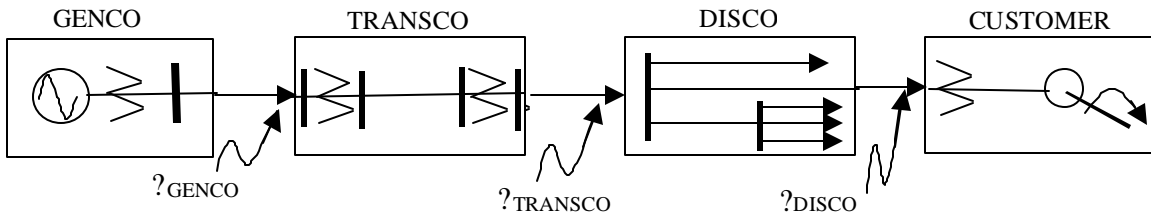

Figure (1) Electric power system controlled by power quality

If it is assumed that power systems are contracted and operated with specified power quality indices, and will be designed and maintained by proper engineering processes to meet required power qualities, each of the elements depicted in Figure (1) can be regarded as a dynamic control system. This control system is 'controlled' by power quality index  $\varphi$ . The concept of a power quality control and variation as a dynamic process is illustrated in Figure (2). In Figure (2), the required (set) power quality level is designated as  $\varphi_{PQ \text{ Required}}$ , and the actual power quality level is  $\varphi_{PQ \text{ Actual}}$ . Other inputs that affect the dynamic character of the power quality are the load ( $L$ ), weather, societal considerations, and engineering decision making. The main point of Figure (2) is that power quality is an interactive-dynamic characteristic of a power system; it is controlled by several stimuli; and there are interactions between costs, engineering, social requirements, and power quality. Note that the 'signal paths' in Figure (2) are actually information flows rather than the usual electrical signals.

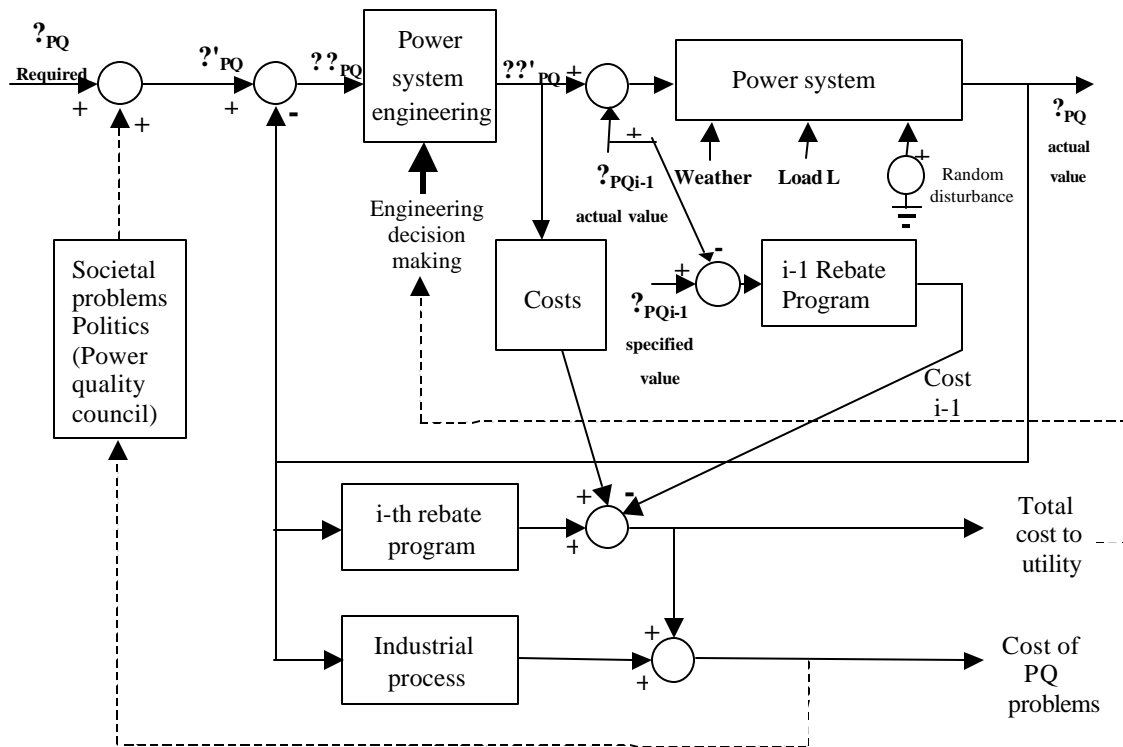

Figure (2) Conceptual diagram of power quality control system

In the proposed power quality infrastructure illustrated in Figure (2) the required power quality level  $\varphi_{PQ \text{ Required}}$  is compared to societal and political issues (i.e., popular acceptance of various levels of power quality). This comparison is qualitative and fuzzy; however the comparison is shown as a summing junction in Figure (2). The resulting level of service,  $\varphi_{PQ}$ , is compared to the actual level of service  $\varphi_{PQ \text{ Actual value}}$ . The difference is applied to a block denoted 'power system engineering' that usually represents power distribution engineering. The power distribution engineering process accepts information from engineering decision making. The result of the entire process entails a cost (labeled 'Costs' in Figure (2)). The resulting required change in power quality level is combined with the previous actual level of power quality, namely  $\varphi_{PQ \text{ actual}}(i-1)$ . The result is assumed to be implemented in the power system. The power system itself receives inputs such as the load and various uncertain inputs such as weather and disturbances. The output resulting from the model is  $\varphi_{PQ \text{ actual value}}$ . One optimistic interpretation of power quality is the total goodness of a power system with the bad traits being eliminated or kept to a minimum. A power quality index should integrate system security, safety, reliability, stability, harmonics, voltage services, and other system response features. Measurement methods are discussed in [12]; power quality indices defined by EN50160 [13] and IEC 1000-3-6/1000-3-7 [14-15] may be used in  $\varphi$ . It may be possible to set power quality indices as a normalized vector through the agreement of suppliers and customers as well as persons who create the standards.

In addition to the basic power quality engineering model indicated above, there is a proposed 'rebate program'. The rebate program is a consequence of the operational power quality level: customers receiving a low level of power quality may receive a 'rebate' to offset their inconvenience. This is shown in Figure (2) as a block labeled 'i-th rebate program', and this is a contributor to the total cost (shown as a summing junction). Participation in the rebate program generates revenue and this is a negative cost in the aforementioned summing junction. The total cost to the utility is indicated in Figure (2). Interruptions to industrial processes are modeled as a block labeled 'Industrial processes' and the total cost of power quality problems is indicated. In some sense, the total cost of power quality problem is 'fed back' as a societal cost. This societal cost is partially a political and subjective matter. For this reason, the societal block in Figure (2) is indicated with dashed input and output paths. Similarly, the engineering decisions in distribution engineering are partially driven by total power quality costs; therefore engineering decision making is driven by a dashed line in Figure (2) from total utility costs.

The process of engineering decision making is important in the design of a power quality engineering infrastructure / procedure. Power quality engineering contains various planning and operational decision making processes. These processes result in optimal facilities investment solutions to provide specified power quality. If there are errors between existing and desired power quality levels, the engineering process will produce a series of alternative plans. Power quality engineering is somewhat different from the usual power system engineering due to specialized power quality requirements. If the requirements are simple and confined to limited customers, such as an industrial customer connected distribution system, the engineering process can give a relatively simple solution [16]. On the contrary, if the requirements are large and system-wide, and the effects of decision making impacts many customers, the solution can be obtained from the solution of a multi-objective operational planning formulation,

$$\text{Min } C(x,y,q,t)$$

subject to system condition, quality limits, financial limits, and time limits where

- $x$  : additional facilities
- $y$  : power system variables(operational cost)
- $q$  : a series of power quality indices
- $t$  : required time to make decision.

Effects on the power system shown in Figure (2) are:

- Load characteristics/variability: most of the variables in power systems are affected by the load characteristics and variations. These inputs can be modeled in a series of composite loads when the system is large (e.g., an entire utility company).
- Disturbances to the power system: weather, accidents, and facility failures can affect the quality of power system. These could be modeled in statistic variables.
- Weather effects and load disturbances as well as system capability.

Depicted in Figure (2), the interactive-dynamic mechanism outputs are:

- The system power quality
- Costs to the utility company: these include the installation and operation costs of new facilities that were designed to assure the specified power quality. Engineering costs to assess the quality and rebate cost also should be included.
- The rebate program for power quality has to be considered on a contractual basis. It is important to make this program so that the utility company makes a proper decision making on power system investments.
- Cost of industry and society by the power quality problem: this output could include the undefined and omitted variables in contracts that make undesirable additional costs in industry.

The required power quality modification is  $\Delta\lambda_{PQ}$  is an input to the power system engineering block: this parameter may be taken as an 'output' because  $\Delta\lambda_{PQ}$  could be decided at the organizational level to reflect the variety opinions of society. To identify the control functions of each block, like decision engineering and cost is not an easy task; but one can regard control functions as artificial intelligent functions with a limited time constant.

### 5. Control mechanism / optimal solution

With the conceptual modeling indicated in the previous section, a power quality control system could be analyzed as multi-objective optimization, to minimize the costs and / or degradation of quality. In Figure (2), it is assumed that supplier and customer agree to a specified power quality index  $I_{PQ}$ . If unacceptable power quality is detected, the power system engineering block will process that signal to produce a series of decisions to achieve the goal of the electric company. This process is depicted in Figure (3).

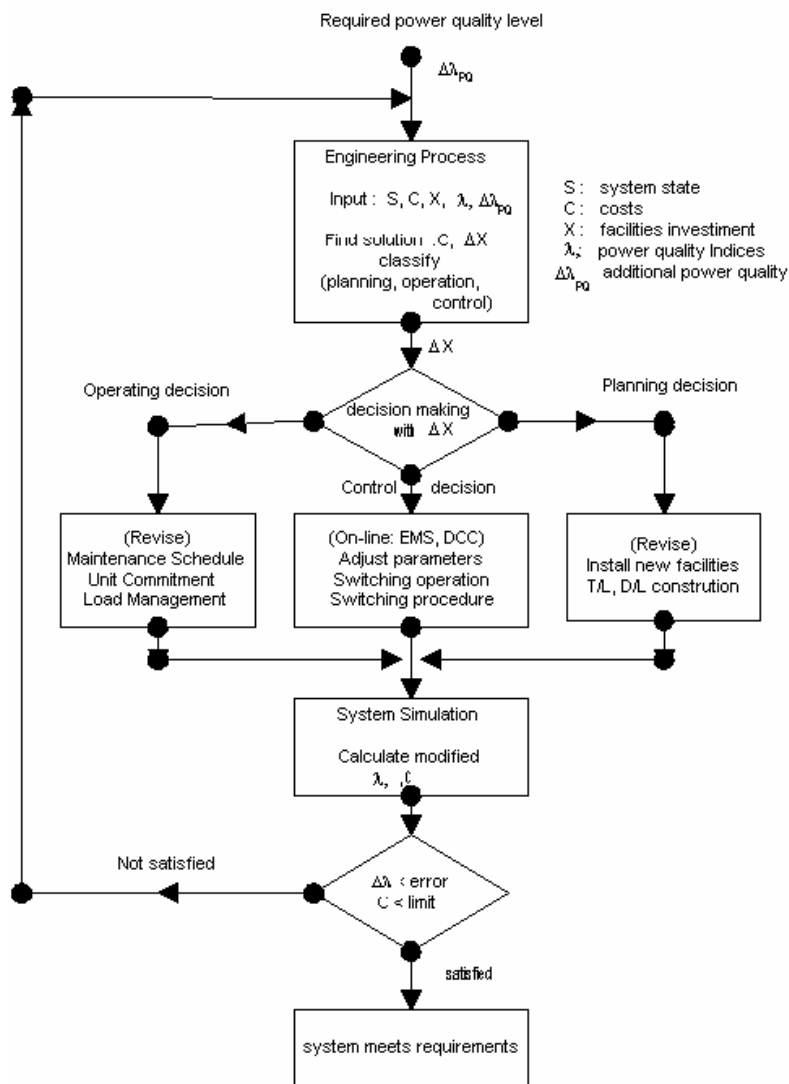

Figure (3) Engineering process for power quality

At the first phase of the engineering process, it is necessary to analyze the power system to convert the error (i.e., deviation of actual system  $\lambda$  from required system  $\lambda_r$ ) into engineering solutions. Several

kinds of steady state and transient analyses including load flow analysis, fault analysis, harmonic analysis, harmonic power flow study, stability analysis and other analyses may be required to identify the causes of error and additional requirements to enhance system performances. With this information, the problem and appropriate countermeasures can be placed in one or more of the following categories: control, operation, planning.

To identify the optimum power quality countermeasure, a cost - benefit analysis is needed which includes all engineering factors. Usually a control process is the cheapest and fastest (and perhaps most acceptable solution by the top decision makers). But the application of controls is often limited by the present system operating facilities and control generally is concomitant with relatively sophisticated engineering technologies. In many actual applications, innovative high technology solutions may give less 'reserve margin' to the set power system response. Operational processes allow additional alternatives to increase power quality by adjusting available system facilities schedule (daily, weekly, monthly basis). The planning process expands system capability by introducing new facilities, but generally, planning requires large budgets and long periods to achieve the desired results.

As the contents of the power quality dynamic - interactive mechanism consists of a series of measurements, software processes and data bases, many component elements can be represented by a simple I/O relation as an artificial intelligence function and / or programs with limited time constants. For example, harmonic voltage quality can be related to the system SSC (short circuit capacity) [19]. These types of interrelationships could make the dynamic - interactive system more tractable. Computer simulation of evaluation of alternative solutions to attain a desired power quality level may be possible. Figure (2) can be treated as a control system which has multi-object optimal solution with respect to power quality index.

## 6. Conclusions

This paper is an overview of a proposed power quality engineering infrastructure. The main point is that decision makers need to balance the issues of cost and quality very carefully: focus on cost alone can produce system response that is unreliable and of poor quality. Also, it is concluded that the power quality engineering process can be represented as an interactive-dynamic mechanism. This mechanism is a starting point for formalizing the engineering process for power quality and potentially securing the proper cost to benefit tradeoff. An engineering process has been suggested for power quality engineering.

## Acknowledgements

The authors thank Professor Richard Farmer for his useful remarks. Also, Dr. Lee thanks Chung Buk Provincial University for permitting his sabbatical leave at Arizona State University.

## References

- [1] Electric Power Research Institute, "The Western states power crisis: imperatives and opportunities," EPRI white paper, June 25, 2001, Palo Alto, CA.
- [2] A. Robert, "Supply quality issues at the interface between power system and industrial consumers," Proceedings of the 8<sup>th</sup> conference on Harmonics and Quality of Power, October 1998, Athens, Greece, pp. 182 - 189.
- [3] W. E. Brumsickle, R. S. Schneider, G. A. Luckjiff, D. M. Divan, M. F. McGranaghan, "Dynamic sag correctors: cost-effective industrial power line conditioning," IEEE Transactions on Industry Applications, v. 37, No. 1, January - February 2001, pp. 212 - 217.
- [4] R. Borlotti, C. Gemme, R. Tinggren, "Integrated power quality in distribution equipment," 16th International Conference and Exhibition (IEE conference publication No. 482) v. 2, 2001, p. 6.
- [5] P. Talacek, N. Watson, "Marginal pricing of harmonic injections," IEEE Transactions on Power Systems, v. 17, No. 1, February 2002, pp. 50 - 56.
- [6] B. Forth, T. Tobin, "Right power, right price," IEEE Computer Applications in Power Magazine, v. 15, No. 2, April 2002, pp. 22 - 27.

- [7] R. Lamedica, G. Esposito, E. Tironi, D. Zaninelli, A. Prudenzi, "A survey on power quality cost in industrial customers," Proceedings of the IEEE Power Engineering Society Winter Meeting 2001, v. 2, pp. 938 - 943.
- [8] M. Sullivan, M. Sheehan, "Observed changes in residential and commercial customer interruption costs in the Pacific Northwest between 1989 and 1999," Proceedings of the IEEE Power Engineering Society Summer Meeting 2000, v. 4, pp. 2290 -2293.
- [9] N. C. Koskolos, S. M. Megaloconomos, E. N. Dialynas, "Assessment of power interruption costs for the industrial customers in Greece," Proceedings of the 8<sup>th</sup> Conference on Harmonics and Quality of Power October, 1998, Athens, Greece, v. 2, pp. 761 - 766.
- [10] W. Golomski, "Reliability and social policy," IEEE Transactions on Reliability, v. 50, No. 2, June 2001, pp. 131-34.
- [11] SRI Consulting, "Appropriate level of loss of load probability for Korea," Technical Project 1116, June, 1999, Seoul, Korea.
- [12] B. Byman, T. Yarborough, "Using distributed power quality monitoring for better electrical system management," IEEE Transactions on Industry Applications, v. 36, No. 5, pp. 1481-1485, September / October, 2000.
- [13] A. Robert, G. Borloo, "Harmonics, flicker and unbalanced measurement using new CIGRE/CIREC recommendations," PQA92, paper E-21, Laborelec, Linkebeek, Belgium, Publication 57-3, June 1993.
- [14] International Electrotechnical Commission IEC 1000-3-6, "Assessment of emission limits for distorting loads in MV and HV power systems," Geneva, 1996.
- [15] International Electrotechnical Commission IEC 1000-3-7, "Assessment of emission limits for fluctuating loads in MV and HV power systems," Geneva, 1996.
- [16] M. Ryan, M. Osborne, "Power quality: a perspective of system problems and solution considerations," IEE Colloquium 28 on Issues in Power Quality, Warwick, UK, pp. 1/1-1/9, November 1995.
- [17] G. T. Heydt, W. T. Jewell, "Pitfalls of electric power quality indices," IEEE Transactions on Power Delivery, v. 13, No. 2, April 1998, pp. 570 - 578.
- [18] A. Chowdhury, D. Koval, "Development of transmission system reliability performance benchmarks," IEEE Transactions on Industry Applications, v. 36, No. 3, May-June 2000, pp. 899 -903.
- [19] K. K. Jensen, J. Knudsen, "Tarification of supplementary short-circuit power needed by a disturbing loads," Proceedings of the Centre International de Recherche sur l'Environnement et le Développement (CIRED) 1991, v. 2, pp. 82-84.
- [20] G. Heydt, "The costs of impaired electric power quality," 1996 IEEE Transmission and Distribution Meeting, September 1996, Los Angeles, CA.
- [21] R. Brown, M. Marshall, "The cost of reliability," Transmission and Distribution, December 2001, pp. 13 - 20.
- [22] M. McGranaghan, "Conference focuses on global power quality issues," Power Quality, September/October 2001, pp. 34-35.